

RELY ON EXCELLENCE

RoTechBooster Service

Ensures optimal performance



To ensure the long-term reliability and operational safety of your EagleBurgmann RoTechBooster, it requires regular maintenance every 24,000 operating hours or every five calendar years, whichever comes first.

Failure to properly maintain the RoTechBooster according to the maintenance instructions in our operating manuals could result in damage to the device and/or connected systems. This could include the generation of high temperatures and/or the release of process gas into the atmosphere. In the worst case, this could lead to a fire or explosion.

Our experienced service engineers are here to answer your questions and will meticulously maintain your RoTechBooster.

Scope of Maintenance

The following work is carried out during regular maintenance:

- Disassembly and cleaning
- Visual inspection of the motor, coupling, and connections/components
- Replacement of the bearing cartridge
- Replacement of static seals
- Maintenance of the electric motor according to the manufacturer's requirements (performed by a certified motor service center)
- Inspection of magnetic coupling, impeller, and housing
- Gas pressure test of the unit
- Functional test of the unit
- Service report

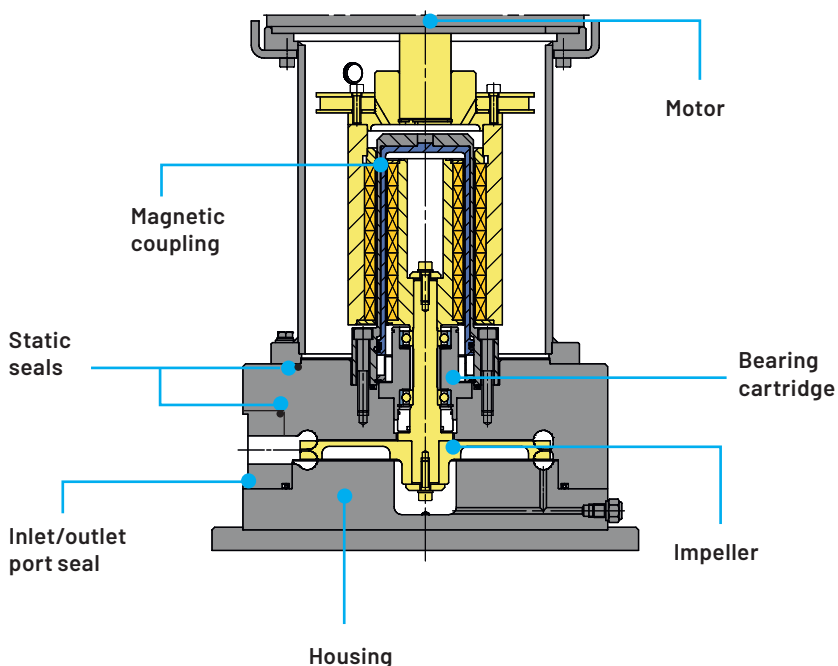

Further information
on RoTechBooster

Recommended Action for Service

- I. To ensure a seamless experience, please **contact your local EagleBurgmann representative**, who will then liaise with the global RoTechBooster service center network.
- II. **Three months prior to the scheduled downtime**, please organize the repair with the service center. This is necessary for scheduling the repair and ensuring the availability of spare parts.
- III. Please **send the RoTechBooster to the service center**, where the recommended maintenance will be performed. The duration is approximately three weeks.

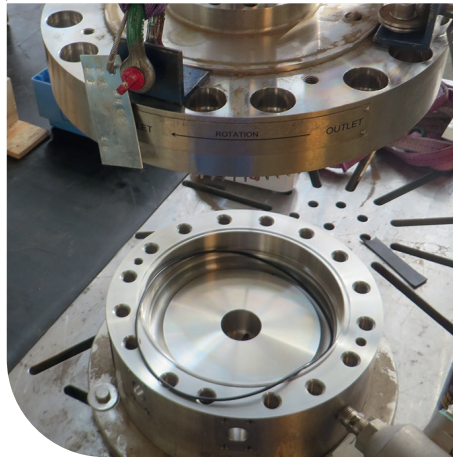
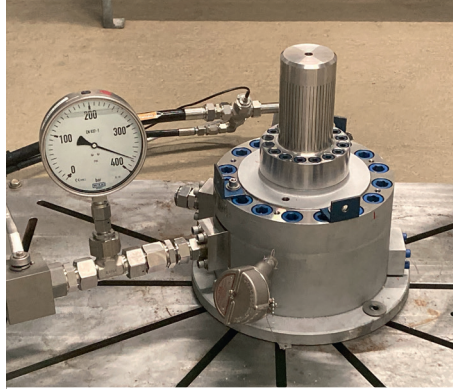

RoTechBooster Service Center

For all matters relating to the regular maintenance of your units, please contact the EagleBurgmann customer service representative responsible for you or our service center in Canada or Germany.

Service Center Canada

EagleBurgmann Canada – Nova Magnetics
118 Cutler Ave.
Dartmouth Nova Scotia B3B 0J6
Canada

Info@novamagnetics.ca
Tel: +1 902 465-6632

Service Center Germany

EagleBurgmann Germany GmbH & Co. KG
Gebäude K503, Passower Chaussee 111
16303 Schwedt/Oder
Germany

dewoh-sc.schwedt@eagleburgmann.com
Tel: +49 3332 2114999

EagleBurgmann – Leading Innovation in Sustainable Sealing Solutions

We are your leading international specialist in industrial sealing technology. We combine innovative technologies, digital solutions and our passion and enthusiasm to create sophisticated and reliable sealing systems. Our products help make entire industries safer and more sustainable. 6,000 employees create added value for our customers around the world with their enthusiasm and competence. EagleBurgmann is a joint venture between the German Freudenberg Group and the Japanese Eagle Industry Group.

Rely on excellence.

eagleburgmann.com
info@eagleburgmann.com

