

RELY ON EXCELLENCE

MA390 / MA391

Mechanical Seals | Mechanical seals for pumps | Standard cartridge seals



Features

- Cartridge
- Balanced
- Independent of direction of rotation
- Stationary multiple springs
- Springs and pin located on the atmospheric side

Advantages

- Ultra-thin compact design – the total length including the seal cover is only 33 mm
- Easy installing on the pumps without modifying the stuffing box
- Excellent followability due to no influence from run-out, squareness or vibration of the shaft
- Mounted outside the stuffing box for providing excellent air cooling performance
- Un-wetted springs and knock pins for protecting from lockout by liquid

Operating range

MA390:

Pressure: $p = \dots 20 \text{ bar (290 PSI)}$

Temperature:

$t = -20 \text{ °C} \dots 160 \text{ °C} (-4 \text{ °F} \dots 320 \text{ °F})$ (oil),

$0 \text{ °C} \dots 60 \text{ °C} (32 \text{ °F} \dots 140 \text{ °F})$ (water)

Sliding velocity:

$vg = \text{max. } 20 \text{ m/s (66 ft/s)}$

Viscosity: $0.5 \text{ Pa}\cdot\text{s}$

Solids content: 0.3%

MA391:

Pressure: $p = \dots 16 \text{ bar (232 PSI)}$

Temperature:

$t = -20 \text{ °C} \dots 160 \text{ °C} (-4 \text{ °F} \dots 320 \text{ °F})$ (oil),

$0 \text{ °C} \dots 60 \text{ °C} (32 \text{ °F} \dots 140 \text{ °F})$ (water)

Sliding velocity: $vg = \text{max. } 20 \text{ m/s (66 ft/s)}$

Viscosity: $3 \text{ Pa}\cdot\text{s}$

Solids content: 10%

Materials

Seal face (MA390): High density carbon graphite

Seal face (MA391): Silicon carbide (Q1)

Seat (MA390/391): Silicon carbide (Q1)

Metal parts: CrNiMo steel (G)

Secondary seals: FKM (V)

Standards and approvals

- EN 12756
- ISO 3096

Recommended applications

- Universally applicable
- Petrochemical industry
- Chemical industry
- Pharmaceutical industry
- Pulp and paper industry
- Water and waste water technology
- Food and beverage industry
- Centrifugal pumps
- Eccentric screw pumps
- Process pumps

RELY ON EXCELLENCE

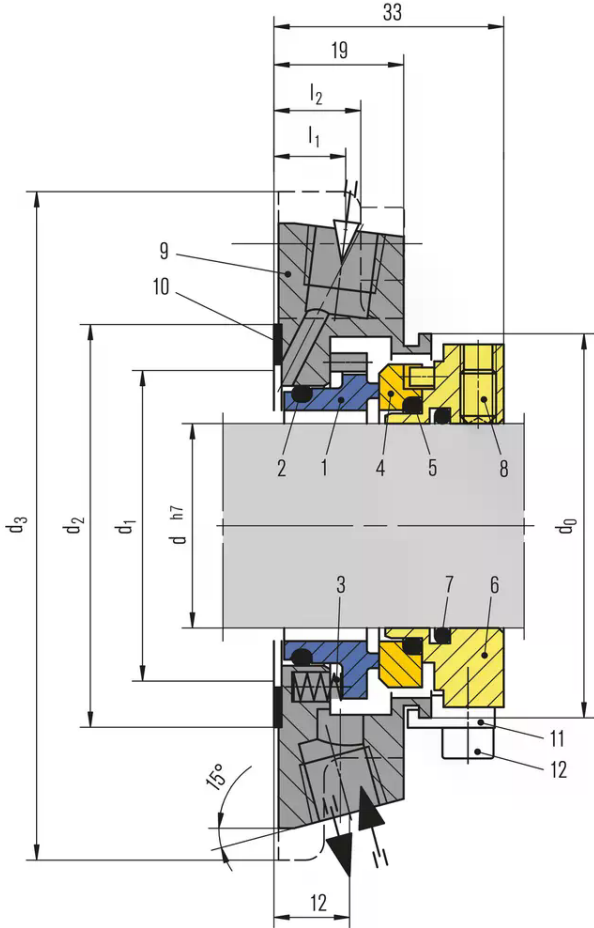

Item	Description
1	Seal face
2, 5, 7	O-Ring
3	Spring
4	Seat
6	Drive collar
8	Set screw
9	Seal cover
10	Gasket
11	Assembly fixture
12	HSH cap screw

Installation, details, options

Seal cover

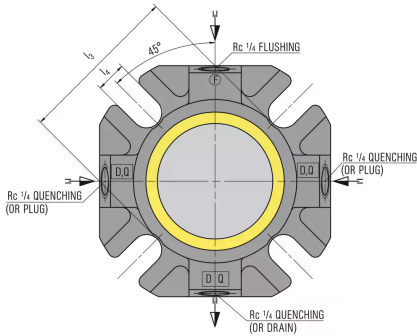

RELY ON EXCELLENCE

Dimensions

d	d ₀	d ₁ min.	d ₁ max.	d ₂	d ₃	l ₁	l ₂	l ₃	l ₄
20	50	35	46	53	104	12	14	53	12
24	55	40	51	58	104	12	14	58	12
25	55	40	51	58	104	12	14	58	12
29	60	45	56	63	108	12	14	63	12
30	60	45	56	63	108	12	14	63	12
35	65	50	61	68	118	12	12	68	14
39	70	55	66	73	118	10	12	73	14
40	70	55	66	73	118	10	12	73	14
45	75	60	71	78	128	10	12	78	14

Dimensions in millimeter