

RELY ON EXCELLENCE

Splitex

Mechanical Seals | Mechanical seals for pumps | Split seals



Features

- Fully split single seal, 2 x 2 segments, pre-assembled
- Semi-cartridge
- Balanced
- Stationary springs
- Bi-directional
- External pressurization
- Built-in flushing connections
- Installation and wear control

Advantages

- Reduced repair and downtime: 2 x 2 pre-assembled design speeds up and simplifies installation because pump does not have to be disassembled.
- Long service life: precise pre-alignment because of pre-assembled segments. Stationary springs which are protected from the product prevent clogging.
- Greater flexibility during installation: no modification necessary because the seal is located outside of the stuffing box.
- Shaft protection: uniform torque transmission via clamping ring prevents damage caused by set screws.
- Dependable operation: mechanical decoupling of clamping ring (torque transmission) avoids distortion of the seat.
- Simple monitoring of the seal during operation because of mechanical wear indicator on the seal face.
- Low leakage: elimination of secondary seals eliminates leakage paths between split components.
- High tolerance to shaft deflections ensured by stationary design and elastic seat mounting (gasket).

Operating range

Shaft diameter:

d1 = 50 ... 150 mm (1.940" ... 6.000")

Pressure: p1 = 10 bar (145 PSI)

Temperature:

t = -40 ... +150 °C (-40 ... +300 °F),

above 80 °C (175 °F) flush is recommended

Sliding velocity: v_g = 10 m/s (33 ft/s)

Axial movement: ±1.5 mm (1/16")

Radial movement: ±0.8 mm (1/32")

Materials

Seal face: Carbon graphite antimony impregnated (A), Silicon carbide (Q6)

Seat: Silicon carbide (Q6)

Secondary seals: FKM (V), EPDM (E), NBR (P)

Springs: CrNiMo steel (G)

Metal parts: CrNiMo steel (G)

Recommended applications

- Process industry
- Petrochemical industry
- Chemical industry
- Power plant technology
- Pulp and paper industry
- Centrifugal pumps
- Agitators
- Displacement pumps
- Conveying pulp with stock pumps
- Conveying timber to refiners with pumping screws
- Circulation of pulp-and-water mixtures in storage vessels
- Pump stations for waste water treatment
- Cooling water pumps for energy generation

RELY ON EXCELLENCE

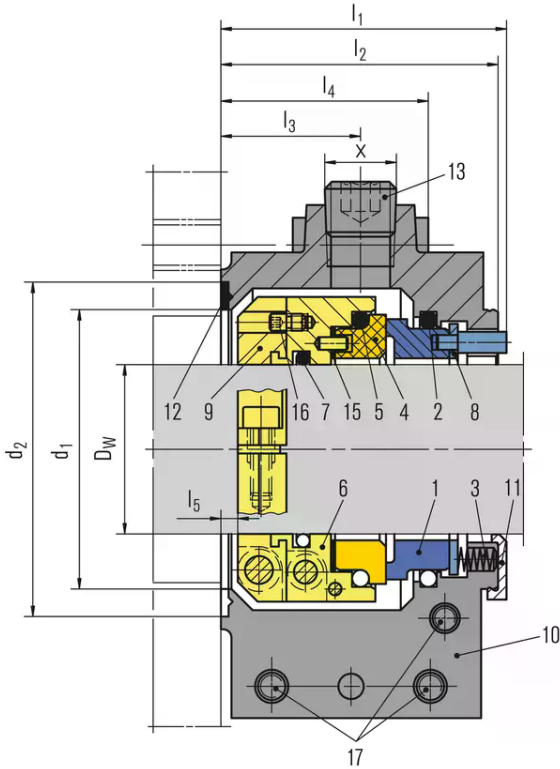

Item	Description
1	Seal face
2, 5, 7	O-Ring
3	Spring
4	Seat
6	Driver
8	Thrust ring
9	Clamp collar
10	Housing
11	Assembly fixture
12, 15	Gasket
13	Head screw plug
14	Mounting plate
16	Set screw
17	Socket head screw

Installation, details, options

Seal cover

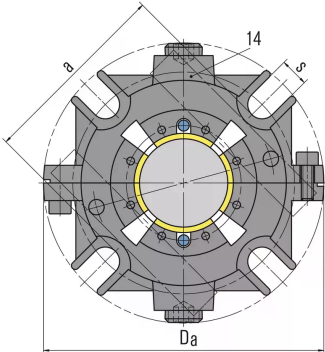

RELY ON EXCELLENCE

Dimensions

d _w	d _w	d ₁	d ₂	d _a	A	s	l ₁	l ₂	l ₃	l ₄	l ₅	X
1.940	49.276	2.953	3.307	5.433	3.456	0.591	2.480	2.402	1.181	1.772	0.118	3/8 NPT
2.000	50.800	2.953	3.307	5.433	3.456	0.591	2.480	2.402	1.181	1.772	0.118	3/8 NPT
2.125	53.975	3.110	3.465	5.787	3.622	0.591	2.480	2.402	1.142	1.772	0.118	3/8 NPT
2.375	60.325	3.504	3.976	5.866	4.134	0.689	2.520	2.441	1.181	1.811	0.118	3/8 NPT
2.438	61.925	3.642	4.114	6.181	4.272	0.689	2.520	2.441	1.181	1.811	0.118	3/8 NPT
2.500	63.500	3.642	4.114	6.181	4.272	0.689	2.520	2.441	1.181	1.811	0.118	3/8 NPT
2.750	69.850	3.858	4.449	6.929	4.646	0.787	2.520	2.441	1.181	1.811	0.118	3/8 NPT
2.938	74.625	4.213	4.803	7.559	5.000	0.787	2.559	2.480	1.299	1.850	0.118	3/8 NPT
3.000	76.200	4.213	4.803	7.559	5.000	0.787	2.559	2.480	1.299	1.850	0.118	3/8 NPT
3.250	82.550	4.331	5.197	7.520	5.315	0.787	2.559	2.480	1.220	1.850	0.118	3/8 NPT
3.500	88.900	4.764	5.512	7.992	5.709	0.866	2.854	2.776	1.240	1.988	0.118	1/2 NPT
3.625	92.075	4.764	5.512	7.992	5.709	0.866	2.854	2.776	1.240	1.988	0.118	1/2 NPT
3.750	95.250	4.921	5.630	8.110	5.827	0.866	2.854	2.776	1.240	1.988	0.118	1/2 NPT
3.875	98.425	5.157	5.906	8.504	6.102	0.866	2.854	2.776	1.240	1.988	0.118	1/2 NPT
4.000	101.600	5.157	5.906	8.504	6.102	0.866	2.854	2.776	1.240	1.988	0.118	1/2 NPT
4.250	107.950	5.591	6.496	9.055	6.693	0.866	2.854	2.776	1.240	1.988	0.118	1/2 NPT
4.500	114.300	5.984	6.890	9.449	7.087	0.866	2.854	2.776	1.240	1.988	0.118	1/2 NPT
4.750	120.650	5.984	6.890	9.449	7.087	0.866	2.854	2.776	1.240	1.988	0.118	1/2 NPT
5.000	127.000	6.378	7.283	10.551	7.480	1.024	3.524	3.445	1.713	2.461	0.157	1/2 NPT
5.500	139.700	6.890	7.874	11.929	8.071	1.024	3.524	3.445	1.713	2.461	0.157	1/2 NPT
6.000	152.400	7.402	8.465	12.126	8.661	1.024	3.524	3.445	1.713	2.461	0.157	1/2 NPT

Dimensions in inch

d _w	d _w	d ₁	d ₂	d _a	a	s	l ₁	l ₂	l ₃	l ₄	l ₅	X
50	1.969	75	84	138	88	15	63	61	30	45	3	3/8 NPT
60	2.362	89	101	149	105	17,5	64	62	30	46	3	3/8 NPT
70	2.756	98	113	176	118	20	64	62	30	46	3	3/8 NPT
80	3.150	110	132	191	135	20	65	63	31	47	3	3/8 NPT
90	3.543	121	140	203	145	22	72.5	70.5	31.5	50.5	3	1/2 NPT
100	3.937	131	150	216	155	22	72.5	70.5	31.5	50.5	3	1/2 NPT
110	4.331	142	165	230	170	22	72.5	70.5	31.5	50.5	3	1/2 NPT
120	4.724	152	175	240	180	22	72.5	70.5	31.5	50.5	3	1/2 NPT
125	4.921	162	185	268	190	26	89.5	87.5	43.5	62.5	4	1/2 NPT
140	5.512	175	200	303	205	26	89.5	87.5	43.5	62	4	1/2 NPT
150	5.906	188	215	308	220	26	89.5	87.5	43.5	62.5	4	1/2 NPT

Dimensions in Millimeter