

RELY ON EXCELLENCE

H7N

Mechanical Seals | Mechanical seals for pumps | Pusher seals



Features

- For stepped shafts
- Single seal
- Balanced
- Super-Sinus-spring or multiple springs rotating
- Independent of direction of rotation
- Integrated pumping device available (H7F, H75F)
- Variant with seat cooling available (H75G115)

Advantages

- Universal application opportunities (standardization)
- Efficient stock keeping due to easily interchangeable faces
- Extended selection of materials
- Flexibility in torque transmissions
- Self cleaning effect
- Short Installation length possible (G16)

Operating range

Shaft diameter:

d1 = 14 ... 100 mm (0.55" ... 3.94")

(Single spring: d1 = max. 100 mm (3.94"))

Pressure:

p1 = 80 bar (1,160 PSI) for d1 = 14 ... 100 mm,

p1 = 25 bar (363 PSI) for d1 = 100 ... 200 mm,

p1 = 16 bar (232 PSI) for d1 > 200 mm

Temperature:

t = -50 °C ... 220 °C (-58 °F ... 428 °F)

Sliding velocity: v_g = 20 m/s (66 ft/s)

Axial movement:

d1 up to 22 mm: ± 1.0 mm

d1 24 up to 58 mm: ± 1.5 mm

d1 from 60 mm: ± 2.0 mm

Materials

Seal face: Silicon carbide (Q1, Q2), Carbon graphite antimony impregnated (A), Aluminium oxide (V), CrMo cast steel (S)

Seat G9: Carbon graphite antimony impregnated (A), Carbon graphite resin impregnated (B), Silicon carbide (Q1*, Q2*)

Secondary seals: EPDM (E), NBR (P), FKM (V), FFKM (K)

Springs: CrNiMo steel (G)

Metal parts: CrNiMo steel (G), Duplex (G1)

* Cannot be combined with seal face made of S

Standards and approvals

- EN 12756

Recommended applications

- Hot water applications
- Light hydrocarbons
- Process industry
- Oil and gas industry
- Refining technology
- Petrochemical industry
- Chemical industry
- Power plant technology
- Pulp and paper industry
- Food and beverage industry
- Boiler feed pumps
- Process pumps

RELY ON EXCELLENCE

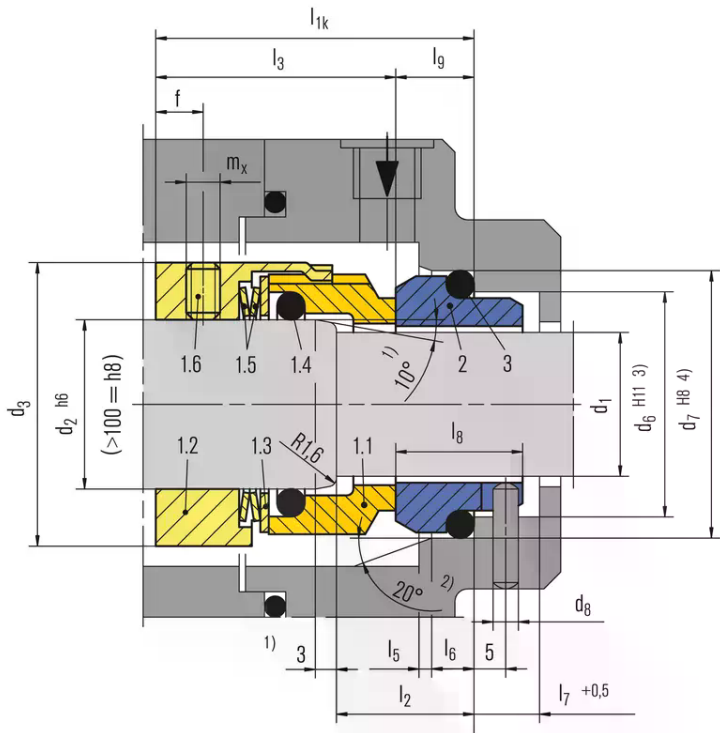

Item	Part no. toDIN 24250	Description
1.1	472	Seal face
1.2	485	Drive collar
1.3	474	Thrust ring
1.4	412.1	O-Ring
1.5	477	Spring
1.6	904	Set screw
2	475	Seat (G9)
3	412.2	O-Ring

- 1) $d_1 > 100$ mm: 2 mm x 30°
- 2) $d_1 > 100$ mm: 30°
- 3) $d_1 > 100$ mm: +0.1
- 4) $d_1 > 100$ mm: H7

RELY ON EXCELLENCE

Seat alternatives

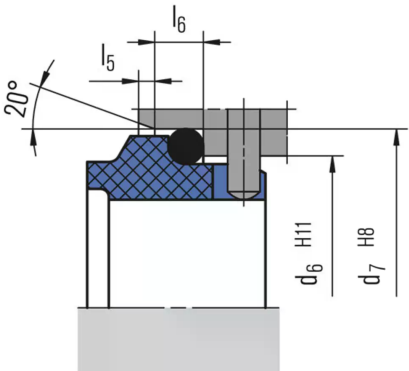

G9
(EN 12756)

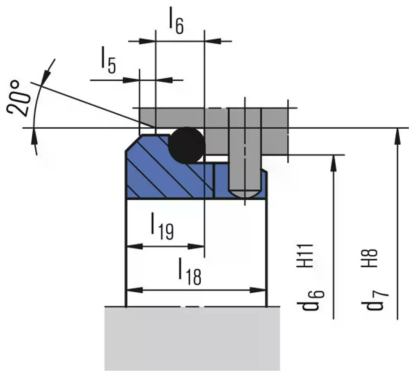

G16
(EN 12756, but l1k and l2 are shorter than specified)

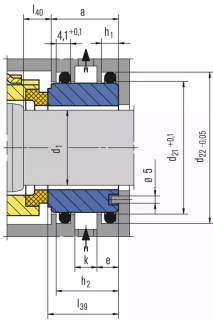

G115
Cooled seat especially for hot water applications.

RELY ON EXCELLENCE

Torque transmissions

$d_1 > 100 \text{ mm}$ (3.94") Torque transmission by 4 set screws with cone point. Offset: 90°

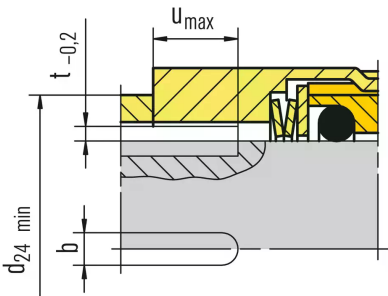
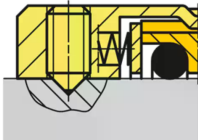

Drive key
(H7S2 / H75S2)

RELY ON EXCELLENCE

Product variants

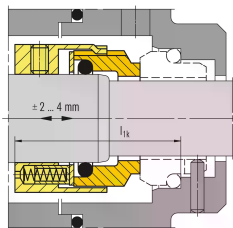

H75

Shaft diameter: $d_1 = 28 \dots 200 \text{ mm}$ (1.10" ... 7.87")

As H7N, but with multiple springs in sleeves (Item no. 1.5)

Axial movement: $\pm 2 \dots 4 \text{ mm}$, dependent on diameter.

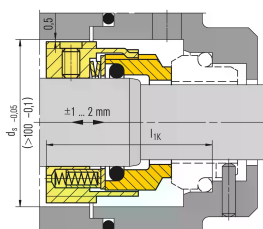

H7F

Shaft diameter: $d_1 = \text{max. } 100 \text{ mm}$ (3.94")

Dimensions, items and descriptions as for H7N, but with single spring and pumping screw.

Dependent on direction of rotation. (Viscosity \leq ISO VG10).

H75F

Shaft diameter: $d_1 = 28 \dots 200 \text{ mm}$ (1.10" ... 7.87")

Dimensions, items and descriptions as for H7N, but with single spring and pumping screw.

Dependent on direction of rotation. (Viscosity \leq ISO VG10).

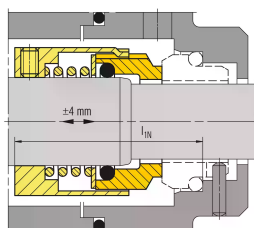

H76

Shaft diameter: $d_1 = 14 \dots 100 \text{ mm}$ (0.55" ... 3.94")

Dimensions, items and description as for H7N, but with special single spring (Item no. 1.5) for compensating large axial movements ($\pm 4 \text{ mm}$).

RELY ON EXCELLENCE

Dimensions

d ₁	d ₂	d ₃	d ₆	d ₇	d ₈	d ₂₄	d ₂₁	d ₂₂	d _s	l _{1K}	l _{1N}	l ₂	l ₃	l ₅	l ₆	l ₇	l ₈	l ₉	l ₃₉	l ₄₀	A	b	e	f	h ₁	h ₂	k	m _x	u _{max}	t
14*	18	33	21.0	25.0	3	20	-	-	38	42.5	-	18	32.5	1.5	4	8.5	17.5	10.0	-	-	-	5	-	6.0	-	-	-	M5	_9	1.1
16*	20	35	23.0	27.0	3	22	-	-	40	42.5	-	18	32.5	1.5	4	8.5	17.5	10.0	-	-	-	5	-	6.0	-	-	-	M5	9	1.1
18*	22	37	27.0	33.0	3	24	-	-	42	45.0	55	20	33.5	2.0	5	9.0	19.5	11.5	-	-	-	6	-	7.0	-	-	-	M5	9	1.5
20*	24	39	29.0	35.0	3	26	-	-	44	45.0	60	20	33.5	2.0	5	9.0	19.5	11.5	-	-	-	6	-	5.5	-	-	-	M5	9	1.5
22*	26	41	31.0	37.0	3	28	-	-	45	45.0	60	20	33.5	2.0	5	9.0	19.5	11.5	-	-	-	6	-	8.0	-	-	-	M5	9	1.5
24*	28	43	33.0	39.0	3	30	-	-	47	47.5	60	20	36.0	2.0	5	9.0	19.5	11.5	-	-	-	6	-	5.5	-	-	-	M6	9	1.5
25*	30	45	34.0	40.0	3	32	-	-	49	47.5	60	20	36.0	2.0	5	9.0	19.5	11.5	-	-	-	6	-	5.5	-	-	-	M6	9	1.5
28*	33	48	37.0	43.0	3	35	44.65	50.57	51	50.0	65	20	38.5	2.0	5	9.0	19.5	11.5	24.0	8.5	24.0	6	8.0	8.0	6.6	22.6	9	M6	12	1.5
30*	35	50	39.0	45.0	3	37	47.83	53.75	54	50.0	65	20	38.5	2.0	5	9.0	19.5	11.5	24.5	9.0	24.0	6	8.0	8.0	6.6	22.6	9	M6	12	1.5
32*	38	55	42.0	48.0	3	40	47.83	53.75	59	50.0	65	20	38.5	2.0	5	9.0	19.5	11.5	24.5	9.0	24.0	6	8.0	8.0	6.6	22.6	9	M6	12	1.5
33*	38	55	42.0	48.0	3	40	47.83	53.75	59	50.0	65	20	38.5	2.0	5	9.0	19.5	11.5	24.5	9.0	24.0	6	8.0	8.0	6.6	22.6	9	M6	12	1.5
35*	40	57	44.0	50.0	3	42	51.00	56.92	61	50.0	65	20	38.5	2.0	5	9.0	19.5	11.5	24.5	9.0	24.0	6	8.0	8.0	6.6	22.6	9	M6	12	1.5
38*	43	60	49.0	56.0	4	45	54.18	60.10	65	52.5	75	23	38.5	2.0	6	9.0	22.0	14.0	26.0	11.0	24.0	6	8.0	8.0	6.6	22.6	9	M6	12	1.5
40*	45	62	51.0	58.0	4	47	60.53	66.45	66	52.5	75	23	38.5	2.0	6	9.0	22.0	14.0	26.0	11.0	24.0	6	8.0	8.0	6.6	22.6	9	M6	12	1.5
43*	48	65	54.0	61.0	4	50	63.70	69.62	69	52.5	75	23	38.5	2.0	6	9.0	22.0	14.0	26.0	11.0	24.0	6	8.0	8.0	6.6	22.6	9	M6	12	1.5
45*	50	67	56.0	63.0	4	52	63.70	69.62	71	52.5	75	23	38.5	2.0	6	9.0	22.0	14.0	26.0	11.0	24.0	6	8.0	8.0	6.6	22.6	9	M6	12	1.5
48*	53	70	59.0	66.0	4	55	66.88	72.80	75	52.5	85	23	38.5	2.0	6	9.0	22.0	14.0	26.0	11.0	24.0	6	8.0	8.0	6.6	22.6	9	M6	12	1.5
50*	55	72	62.0	70.0	4	57	70.05	75.97	76	57.5	85	25	42.5	2.5	6	9.0	23.0	15.0	26.5	12.5	24.0	6	8.0	8.0	6.6	22.6	9	M6	12	1.5
53*	58	79	65.0	73.0	4	60	76.40	82.32	83	57.5	85	25	42.5	2.5	6	9.0	23.0	15.0	26.5	12.5	24.0	8	8.0	9.0	6.6	22.6	9	M8	12	1.9
55*	60	81	67.0	75.0	4	62	76.40	82.32	85	57.5	85	25	42.5	2.5	6	9.0	23.0	15.0	28.5	12.5	26.0	8	8.0	9.0	6.6	24.6	11	M8	12	1.9
58*	63	84	70.0	78.0	4	65	79.58	85.50	88	62.5	85	25	47.5	2.5	6	9.0	23.0	15.0	28.5	12.5	26.0	8	8.0	9.0	6.6	24.6	11	M8	15	1.9
60*	65	86	72.0	80.0	4	67	82.75	88.67	95	62.5	95	25	47.5	2.5	6	9.0	23.0	15.0	28.5	12.5	26.0	8	8.0	9.0	6.6	24.6	11	M8	15	1.9
63*	68	89	75.0	83.0	4	70	85.93	91.85	93	62.5	95	25	47.5	2.5	6	9.0	23.0	15.0	28.5	12.5	26.0	8	8.0	9.0	6.6	24.6	11	M8	14	1.9
65*	70	91	77.0	85.0	4	72	85.93	91.85	95	62.5	95	25	47.5	2.5	6	9.0	23.0	15.0	28.5	12.5	26.0	8	8.0	9.0	6.6	24.6	11	M8	15	1.9
70*	75	99	83.0	92.0	4	77	89.10	95.02	105	70.0	95	28	52.0	2.5	7	9.0	26.0	18.0	30.5	14.5	26.0	8	8.0	10.0	6.6	24.6	11	M8	15	1.9
75*	80	104	88.0	97.0	4	82	98.63	104.55	109	70.0	105	28	52.0	2.5	7	9.0	26.0	18.0	30.5	14.5	26.0	8	8.0	10.0	6.6	24.6	11	M8	15	1.9
80*	85	109	95.0	105.0	4	87	101.80	107.72	114	70.0	105	28	51.8	3.0	7	9.0	26.2	18.2	30.2	14.0	26.0	8	8.0	10.0	6.6	24.6	11	M8	15	1.9
85*	90	114	100.0	110.0	4	92	108.15	114.07	119	75.0	105	28	56.8	3.0	7	9.0	26.2	18.2	30.2	14.0	26.0	10	8.0	10.0	6.6	24.6	11	M8	18	2.3
90*	95	119	105.0	115.0	4	97	114.50	120.42	124	75.0	105	28	56.8	3.0	7	9.0	26.2	18.2	30.2	14.0	26.0	10	8.0	10.0	6.6	24.6	11	M8	18	2.3
95*	100	124	110.0	120.0	4	102	117.68	123.60	129	75.0	105	28	57.8	3.0	7	9.0	25.2	17.2	29.2	14.0	26.0	10	8.0	10.0	6.6	24.6	11	M8	18	2.3
100*	105	129	115.0	125.0	4	107	124.03	129.95	134	75.0	105	28	57.8	3.0	7	9.0	25.2	17.2	29.2	14.0	26.0	10	8.0	10.0	6.6	24.6	11	M8	18	2.3
105*	115	148	122.2	134.3	5	118	128.98	134.90	153	73.0	-	32	53.0	2.0	10	-	30.0	20.0	29.2	15.2	26.0	10	8.0	10.0	6.6	24.6	11	M8	18	2.3
110*	120	153	128.2	140.3	5	123	135.30	141.20	158	73.0	-	32	53.0	2.0	10	-	30.0	20.0	32.5	14.5	30.0	10	9.5	10.0	6.6	28.6	13	M8	18	2.3
115*	125	158	136.2	148.3	5	128	140.30	146.20	163	73.0	-	32	53.0	2.0	10	-	30.0	20.0	32.5	14.5	30.0	10	9.5	10.0	6.6	28.6	13	M8	18	2.3
120*	130	163	138.2	150.3	5	133	145.30	151.20	168	73.0	-	32	53.0	2.0	10	-	30.0	20.0	32.5	14.5	30.0	10	9.5	10.0	6.6	28.6	13	M8	18	2.3
125*	135	168	142.2	154.3	5	138	150.30	156.20	173	73.0	-	32	53.0	2.0	10	-	30.0	20.0	32.5	14.5	30.0	10	9.5	10.0	6.6	28.6	13	M8	18	2.3
130*	140	173	146.2	158.3	5	143	155.30	161.20	178	73.0	-	32	53.0	2.0	10	-	30.0	20.0	32.5	14.5	30.0	10	9.5	10.0	6.6	28.6	13	M8	18	2.3
135*	145	178	152.2	164.3	5	148	160.30	166.20	183	73.0	-	32	53.0	2.0	10	-	30.0	20.0	32.5	14.5	30.0	10	9.5	10.0	6.6	28.6	13	M8	18	2.3
140*	150	183	156.2	168.3	5	153	165.30	171.20	188	73.0	-	32	53.0	2.0	10	-	30.0	20.0	32.5	14.5	30.0	10	9.5	10.0	6.6	28.6	13	M8	18	2.3
145*	155	191	161.2	173.3	5	158	172.30	178.20	196	83.0	-	34	63.0	2.0	10	-	30.0	20.0	34.5	16.5	32.0	12	10.0	12.0	7.1	30.1	14	M8	22	2.1
150*	160	196	168.2	180.3	5	163	177.30	183.20	201	85.0	-	36	63.0	2.0	10	-	32.0	22.0	34.5	16.5	32.0	12	10.0	12.0	7.1	30.1	14	M8	22	2.1
155*	165	201	173.2	185.3	5	168	182.30	188.20	206	87.0	-	38	63.0	2.0	12	-	34.0	24.0	34.5	16.5	32.0	12	10.0	12.0	7.1	30.1	14	M8	22	2.1
160*	170	206	178.2	190.3	5	173	187.30	193.20	211	87.0	-	38	63.0	2.0	12	-	34.0	24.0	34.5	16.5	32.0	12	10.0	12.0	7.1	30.1	14	M8	22	2.1
165*	175	211	183.2	195.3	5	178	192.30	198.20	216	87.0	-	38	63.0	2.0	12	-	34.0	24.0	34.5	16.5	32.0	12	10.0	12.0	7.1	30.1	14	M8	22	2.1
170*	180	216	188.2	200.3	5	183	197.30	203.20	221	87.0	-	38	63.0	2.0	12	-	34.0	24.0	37.0	16.5	34.5	12	10.0	12.0	7.1	32.1	16	M8	22	2.1
175*	185	221	193.2	205.3	5	188	202.30	208.20	226	87.0	-	38	63.0	2.0	12	-	34.0	24.0	37.0	16.5	34.5	12	10.0	12.0	7.1	32.1	16	M8	22	2.1
180*	190	226	207.5	219.3	5	193	207.30	213.20	231	91.0	-	42	63.0	2.0	12	-	38.0	28.0	37.0	16.5	34.5	12	10.0	12.0	7.1	32.1	16	M8	22	2.1
185*	195	231	212.5	224.3	5	198	212.30	218.20	236	91.0	-	42	63.0	2.0																

RELY ON EXCELLENCE

d ₁	d ₂	d ₃	d ₆	d ₇	d ₈	d ₂₄	d ₂₁	d ₂₂	d _s	l _{1K}	l _{1N}	l ₂	l ₃	l ₅	l ₆	l ₇	l ₈	l ₉	l ₃₉	l ₄₀	A	b	e	f	h ₁	h ₂	k	m _x	u _{max}	t
195*	205	245	222.5	234.2	5	208	225.30	231.20	250	94.0	-	43	66.0	2.0	12	-	38.0	28.0	37.0	17.5	34.5	12	10.0	14.0	7.1	32.1	16	M10	22	2.1
200*	210	250	227.5	239.3	5	213	230.30	236.20	255	94.0	-	43	66.0	2.0	12	-	38.0	28.0	37.0	17.5	34.5	12	10.0	14.0	7.1	32.1	16	M10	22	2.1

Dimensions in millimeter * EN 12756