

RELY ON EXCELLENCE

MFLCT8

Mechanical Seals | Mechanical seals for pumps | Metal Bellow seals



Features

- For unstepped shafts
- Single seal
- Balanced
- Independent of direction of rotation
- Metal bellows rotating

Advantages

- For extreme cold temperature ranges
- No dynamically loaded O-Ring
- Self cleaning effect
- Short installation length possible
- Pumping screw for highly viscous media available (dependant on direction of rotation).

Operating range

Shaft diameter:

d1 = 24 ... 150 mm (0.94" ... 6")

Externally pressurized:

p1 = ... 25 bar (363 PSI)

Internally pressurized:

p1 = 10 bar (145 PSI),

stationary seat lock necessary.

Temperature:

t = -100 °C ... +100 °C (-148 °F ... 212) °F

Sliding velocity: v_g = 20 m/s (66 ft/s)

Materials

Seal face: Carbon graphite antimony impregnated (A), Silicon carbide (Q12)

Seat: Silicon carbide (Q1)

Bellows: Inconel® 718 hardened (M6), Hastelloy® C-276 (M5)

Metal parts: CrNiMo steel (G), Hastelloy® C-4 (M)

Recommended applications

- Cold media
- Highly viscous media
- Process industry
- Oil and gas industry
- Refining technology
- Petrochemical industry
- Chemical industry
- LNG
- CCUS
- Pumps
- Special rotating equipment

RELY ON EXCELLENCE

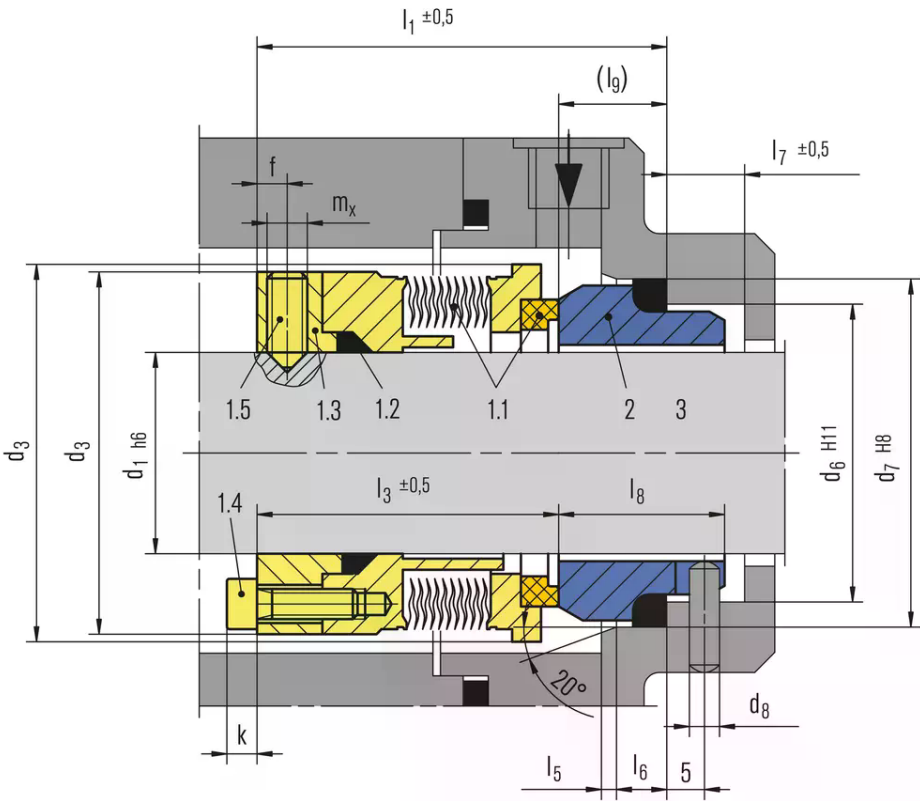

Item	Part no.DIN 24250	Description
1.1	472/481	Seal face with bellows unit
1.2	410	Sealing ring
1.3	474	Drive collar
1.4		Socket head screw
1.5	904	Set screw
2	475	Seat
3	412	Sealing ring

Product variants

MFLCT9

Shaft diameter:

d1 = 20 ... 150 mm (0.64" ... 6")

Intenally pressurized:

p1 = ... 16 bar (232 PSI),

stationary seat lock necessary.

Externally pressurized:

p1 = 10 bar (145 PSI)

Temperature:

t = -100 °C ... +100 °C

(-148 °F ... +212 °F)

Sliding velocity: vg = 20 m/s (66 ft/s)

RELY ON EXCELLENCE

Dimensions

d ₁	d ₃	d ₃₍₂₎	d ₆	d ₇	d ₈	l ₁	l ₃	l ₅	l ₆	l ₇	l ₈	l ₉	f	k	m _x
16	38	-	29.0	35.0	3	58.0	46.5	2.0	5	9	19.5	11.5	5	5	M5
18	40	-	31.0	37.0	3	58.0	46.5	2.0	5	9	19.5	11.5	5	5	M5
20	42	-	34.0	40.0	3	58.0	46.5	2.0	5	9	19.5	11.5	5	5	M5
22	44	-	37.0	43.0	3	58.0	46.5	2.0	5	9	19.5	11.5	5	5	M5
24	46	49.8	37.0	43.0	3	58.0	46.5	2.0	5	9	19.5	11.5	5	5	M5
25	47	51.7	39.0	45.0	3	58.0	46.5	2.0	5	9	19.5	11.5	5	5	M5
28	50	54.5	42.0	48.0	3	58.0	46.5	2.0	5	9	19.5	11.5	5	5	M6
30	52	56.6	44.0	50.0	3	58.0	46.5	2.0	5	9	19.5	11.5	5	5	M6
32	54	59.5	49.0	56.0	4	60.5	46.5	2.0	6	9	22.0	14.0	5	5	M6
33	55	59.5	49.0	56.0	4	60.5	46.5	2.0	6	9	22.0	14.0	5	5	M6
35	57	62.5	51.0	58.0	4	60.5	46.5	2.0	6	9	22.0	14.0	5	5	M6
38	60	65.7	54.0	61.0	4	60.5	46.5	2.0	6	9	22.0	14.0	5	5	M6
40	66	65.7	56.0	63.0	4	61.5	47.5	2.0	6	9	22.0	14.0	5	6	M6
43	69	68.6	59.0	66.0	4	61.5	47.5	2.0	6	9	22.0	14.0	5	6	M6
45	71	71.5	62.0	70.0	4	62.5	47.5	2.5	6	9	23.0	15.0	5	6	M6
48	74	75.1	65.0	73.0	4	62.5	47.5	2.5	6	9	23.0	15.0	5	6	M6
50	76	76.1	67.0	75.0	4	62.5	47.5	2.5	6	9	23.0	15.0	5	6	M6
53	79	80.8	70.0	78.0	4	62.5	47.5	2.5	6	9	23.0	15.0	5	6	M6
55	81	80.8	72.0	80.0	4	62.5	47.5	2.5	6	9	23.0	15.0	5	6	M6
58	85	84.0	75.0	83.0	4	68.0	53.0	2.5	6	9	23.0	15.0	5	6	M6
60	87	92.3	77.0	85.0	4	68.0	53.0	2.5	6	9	23.0	15.0	6	6	M8
63	90	95.5	81.0	90.0	4	71.0	53.0	2.5	7	9	26.0	18.0	6	6	M8
65	92	95.5	83.0	92.0	4	71.0	53.0	2.5	7	9	26.0	18.0	6	6	M8
68	95	101.3	88.0	97.0	4	71.0	53.0	2.5	7	9	26.0	18.0	6	6	M8
70	97	101.3	88.0	97.0	4	71.0	53.0	2.5	7	9	26.0	18.0	6	6	M8
75	102	105.0	95.0	105.0	4	71.0	52.8	3.0	7	9	26.2	18.2	6	6	M8
80	107	110.6	100.0	110.0	4	71.0	52.8	3.0	7	9	26.2	18.2	6	6	M8
85	112	117.0	105.0	115.0	4	71.0	52.8	3.0	7	9	26.2	18.2	6	6	M8
90	117	120.2	110.0	120.0	4	71.0	53.8	3.0	7	9	25.2	17.2	6	6	M8
95	122	125.2	115.0	125.0	4	71.0	53.8	3.0	7	9	25.2	17.2	6	6	M8
100	127	130.2	122.2	134.3	5	74.0	54.0	3.0	9	11	30.0	20.0	6	6	M8

Dimensions in millimeter 2) d~3~ executed in Hastelloy®