

RELY ON EXCELLENCE

GSO-DN

Mechanical Seals | Mechanical seals for pumps | Gas-lubricated seals



Features

- Seat rotating
- Stationary springs
- Double seal
- Balanced
- Standard version with V-grooves, U-grooves optional (independent of direction of rotation)
- Gas-lubricated

Advantages

- Contact free operation
- Face-to-face
- Cartridge unit
- Does not open in the event of buffer pressure failure
- Self closing at pressure reversal
- No additional complex components to dissipate frictional heat

Operating range

Shaft diameter:

$d_1 = 30 \dots 75 \text{ mm}$ (1,125" ... 2,625")
(other dimensions on request)

Product pressure:

$p_1 = \text{max. } 22 \text{ bar}$ (319 PSI),
(dependent on shaft diameter and sliding materials)

Barrier pressure: $p_3 = \text{max. } 25 \text{ bar}$ (362 PSI),
Differential pressure: $\Delta p = \text{min. } 3 \text{ bar}$ (44 PSI)

Temperature:

$t = -20 \text{ }^\circ\text{C} \dots +170 \text{ }^\circ\text{C}$ (-4 °F ... +338 °F)
(dependent on resistance of O-Rings)

Sliding velocity: $v_g = 16 \text{ m/s}$ (52 ft/s),
with special design max. 25 m/s (82 ft/s)

Axial movement: $\pm 0.2 \text{ mm}$

Materials

Seal faces: Carbon graphite (A)

Seat: Silicon carbide (Q1, Q2)

Secondary seals:

FKM (V), EPDM (E), FFKM (K)

Springs: Hastelloy® C-4 (M)

Metal parts:

CrNiMo steel (G), Hastelloy® C-4 (M)

Recommended applications

- Gases and liquids
- Media which require high purity
- Environmental harmful media
- Chemical industry
- Refining technology
- Blowers
- Fans
- Pumps

RELY ON EXCELLENCE

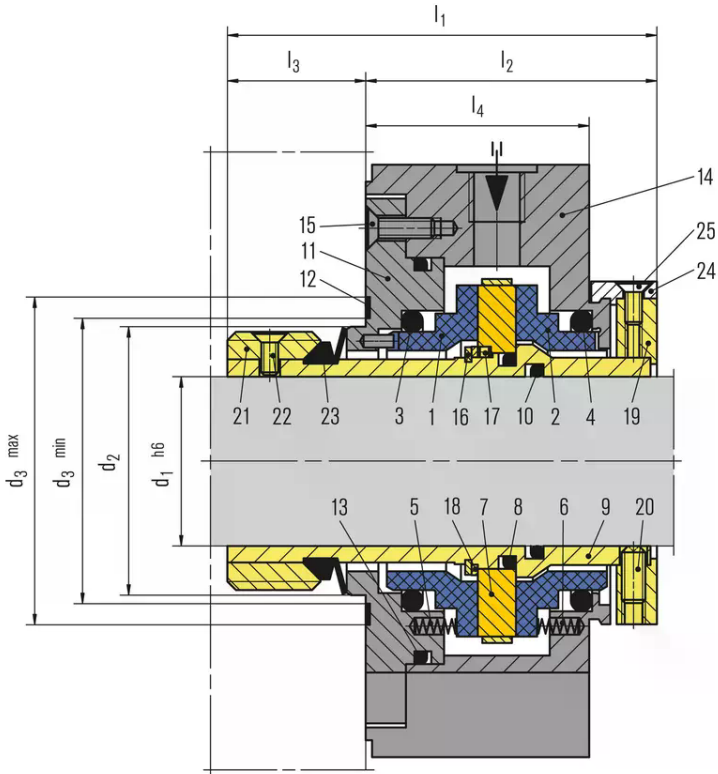

Item	Description
1, 2	Seal face
3, 4, 8, 10, 13	O-Ring
5, 6	Spring
7	Seat
9	Shaft sleeve
11	Flange
12	Gasket
14	Cover
15, 22, 25	Countersunk screw
16	Retaining ring
17	Pin
18	Ring
19	Set ring
20	Set screw
21	Pumping ring
23	V-Seal
24	Assembly fixture

Installation, details, options

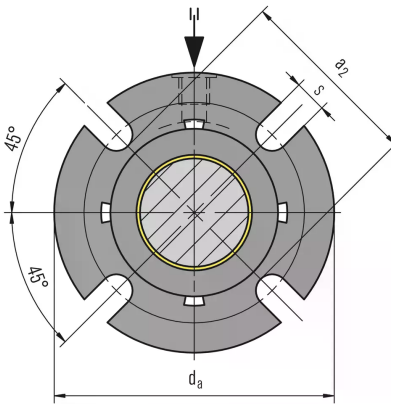

Seal cover

RELY ON EXCELLENCE

Dimensions

Type	d ₁	d ₂	d ₃ min.	d ₃ max.	l ₁	l ₂	l ₃	l ₄	d _a	a ₂	s
GSO-DN/30-00-R	30	46	49	59	85	55	30	39	104	69.7	14
GSO-DN/33-00-R	33	49	53	65	85.5	55.5	30	39.5	122	72.7	14
GSO-DN/35-00-R	35	51	52	65	85.5	55.5	30	39.5	124	74.7	14
GSO-DN/43-00-R	43	63	64	78	90.5	57.5	33	41.5	138	84.7	16
GSO-DN/48-00-R	48	69	69	80	90.5	57.5	33	41.5	145	89.7	16
GSO-DN/50-00-R	50	70	72	82	90.5	57.5	33	41.5	147	91.7	16
GSO-DN/53-00-R	53	73	73	87	92.8	57.8	35	41.8	148	94.7	18
GSO-DN/60-00-R	60	85	87	102	97.5	60.5	37	44.5	157	104	18
GSO-DN/65-00-R	65	90	91	107	100.5	59.5	41	43.5	178	109	18

Dimensions in millimeter Other diameters on request.