

RELY ON EXCELLENCE

eMG1

Mechanical Seals | Mechanical seals for pumps | Elastomer bellow seals



Features

100 % compatible with MG1

- Small outer diameter of bellows support (dbmin) enables direct retaining ring support, or smaller spacer rings
- Optimal alignment characteristic through self-cleaning of disk/shaft
- Improved centering across entire pressure operating range
- No torsion on bellows
- Shaft protection over entire seal length
- Protection of seal face during installation due to special bellows design
- Insensitive to shaft deflections due to large axial movement ability
- Suitable for low-end sterile applications

Notes

The eMG1 can also be used as a multiple seal in tandem or in a back-to-back arrangement, please inquire. Other materials and designs available on request.

Advantages

- For plain shafts
- Single and dual seal
- Elastomer bellows rotating
- Balanced
- Independent of direction of rotation

Operating range

Shaft diameter:

d1 = 14 ... 110 mm (0.55" ... 4.33")

Pressure: p1 = 18 bar (261 PSI),

vacuum ... 0.5 bar (7.25 PSI),

up to 1 bar (14.5 PSI) with seat locking

Temperature: t = -20 °C ... +140 °C

(-4 °F ... +284 °F)

Sliding velocity: vg = 10 m/s (33 ft/s)

Admissible axial movement: ±2.0 mm (±0.08")

Materials

Seal face: Carbon graphite antimony impregnated (A), Carbon graphite resin impregnated (B), Silicon carbide (eSiC-Q7)

Seat: Silicon carbide (eSiC-Q7, Q1)

Elastomer: NBR (P), EPDM (E), FKM (V), HNBR (X4)

Metal parts: CrNiMo steel (G), Hastelloy® (M)

Standards and approvals

Various material approvals available (depending on type and material combinations). Please inquire!

- FDA
- UBA (KTW)
- ACS
- W270

Recommended applications

- Fresh water supply
- Building services engineering
- Waste water technology
- Food and beverage industry
- Sugar production
- Pulp and paper industry
- Oil industry
- Petrochemical industry
- Chemical industry
- Chemical standard pumps
- Helical screw pumps
- Stock pumps
- Circulating pumps
- Submersible pumps
- Water and waste water pumps
- Water, waste water, slurries (solids up to 5 % by weight)
- Pulp (up to 4 % otro)
- Latex
- Dairies, beverages
- Sulfide slurries

RELY ON EXCELLENCE

- Chemicals
- Oils

eMG1

Item	Description
1.1	Seal face
1.2	Bellows
1.3	Set of springs
1.4	PEEK-PTFE disk
2	Seat (G6)
3	O-Ring or cup rubber

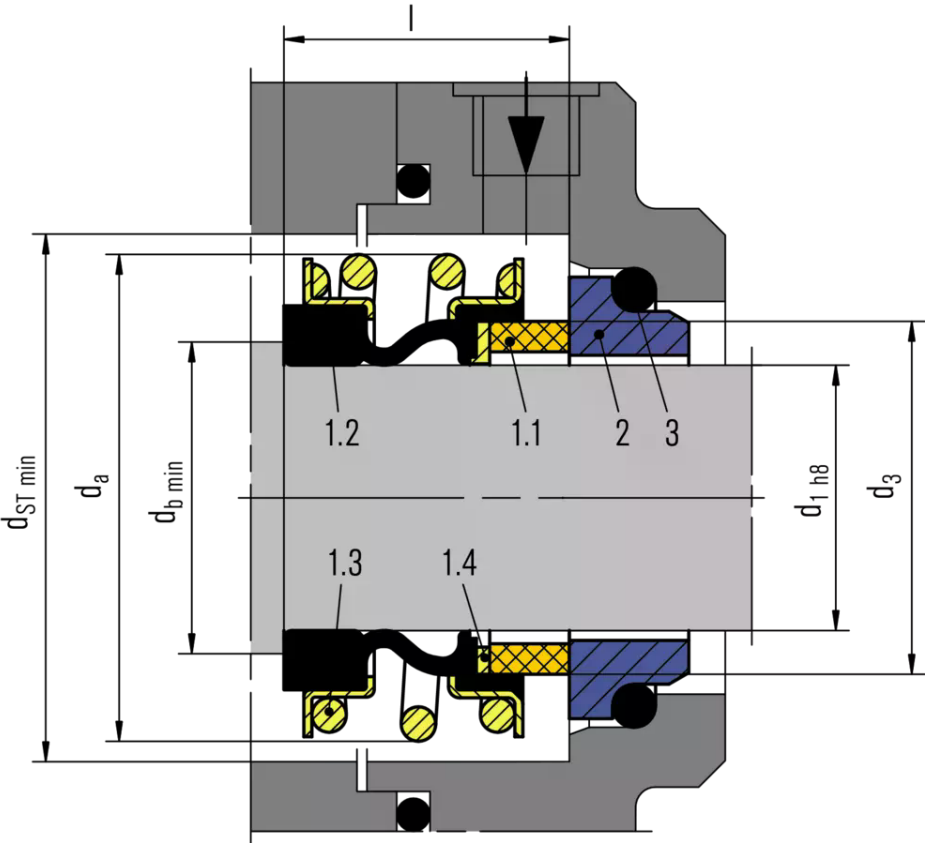

eMG1 © EagleBurgmann

RELY ON EXCELLENCE

Seat alternatives

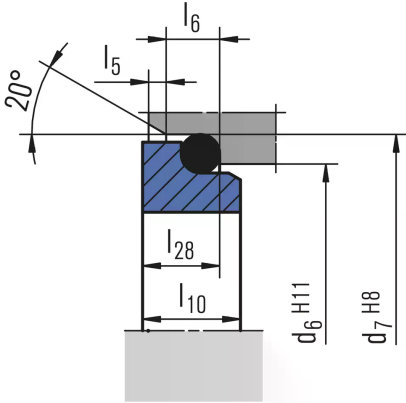

G6 \n EN 12756

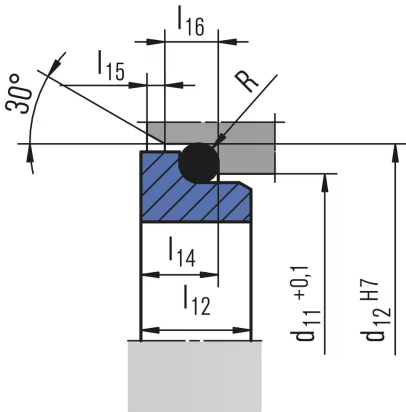

G4 (optional)

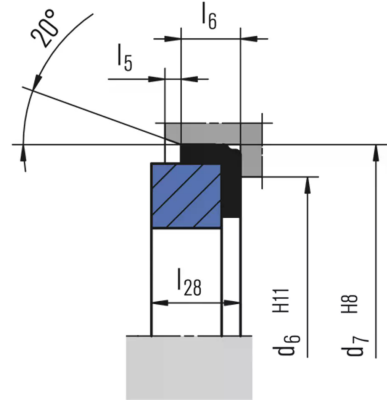

G60 (optional) \n EN 12756

RELY ON EXCELLENCE

Product variants

eRMG1

Identical to eMG1, but with a special bellows surface on the shaft side. For use in hot water pumps

d1 = 14 ... 38 mm (0.55" ... 1.50")
Seat G6: Silicon carbide (eSiC-Q7)

A/eSiC-Q7:
120 °C (248 °F) and 25 bar (363 PSI) 140 °C (284 °F) and 16 bar (232 PSI)

B/eSiC-Q7:
120 °C (248 °F) and 18 bar (161 PSI)

eSiC-Q7/eSiC-Q7:
120 °C (248 °F) and 18 bar (161 PSI)

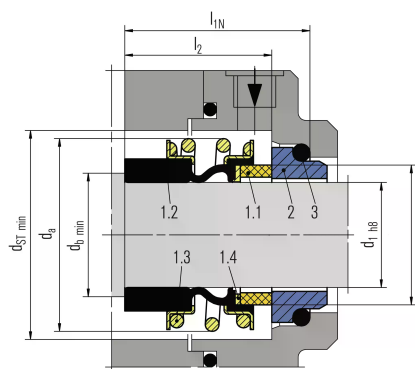

eMG13

Dimensions, items and designations same as for eMG1, but with an extended bellows tail to achieve the fitting length l1N according to EN 12756 in combination with seat G6 or G60 (da exceeds EN 12756).

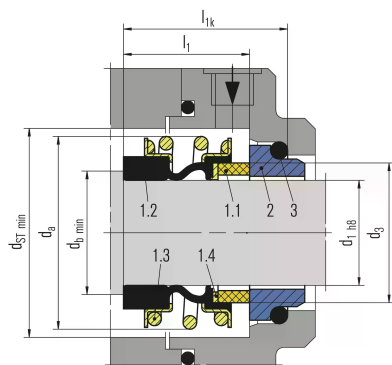

eMG12

Dimensions, items and designations same as for eMG1, but with an extended bellows tail to achieve the fitting length l1k according to EN 12756 in combination with seat G6 or G60 (da exceeds EN 12756).

RELY ON EXCELLENCE

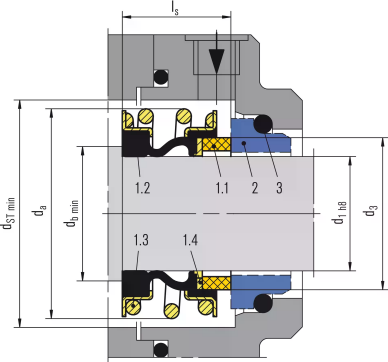

eMG \n
Dimensions, items and designations same as for eMG1, but with an shortened bellows tail to achieve the fitting length IS. Shortest fitting length.