

RELY ON EXCELLENCE

## MagBlower model 172

### Blowers



#### Features

- Hermetically sealed
- No contamination of process
- No process gas to atmosphere
- Always below 85 dBA noise levels
- Low heat generation and high torque transfer magnetic coupling
- Pulsation free gas flow
- Engineered designs available to meet special requirements

#### Functional description

The Magnetic coupling allows power transfer from the electric motor to the impeller without mechanical contact; eliminating the need for a shaft seal. The bearings suitable for the application support the impeller shaft in the blower housing. The gas enters the blower and the energy put into the gas from the blower impeller, produces flow and a pressure increase as required for the application before exiting the blower outlet.

#### Notes

Options:

- Horizontal or vertical design
- Centrifugal or regenerative impeller

#### Advantages

- The MagBlower delivers abundant, reliable, and consistent gas flow, in every situation with no leakage.
- Simple to set-up, easy to operate
- High reliability and availability
- Designed for continuous operation
- Low maintenance costs
- Energy efficient

#### Operating range

Pressure: Vacuum ... 69 bar (100 PSI)

Temperature:

-40 °C ... +200 °C (-40 °F ... +392 °F)

Head: ... 4 Kpa (0.55 PSI) on air

Flow: 275 m<sup>3</sup>/h (162 CFM) on air

Models outside of these operating ranges are available on request.

#### Recommended applications

- Oil and gas industry
- Refining technology
- Chemical industry
- Petrochemical industry
- Pharmaceutical industry
- Nuclear applications
- Research
- Manufacturing
- Vapor recovery

## RELY ON EXCELLENCE

- Single to four stage in series or parallel
- Bearings to meet application requirements
- Noise reduction cover

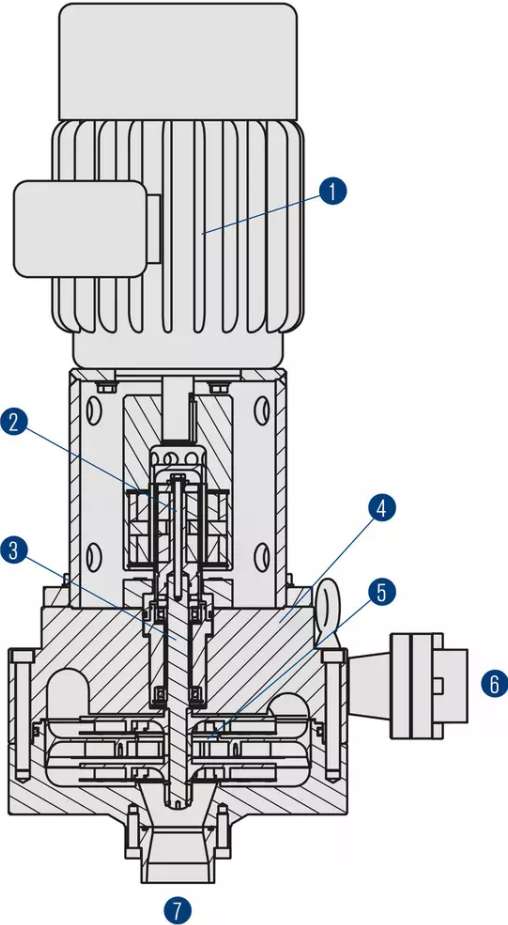

Item	Description
1	Motor
2	Magnetic coupling
3	Bearing assembly
4	Blower housing
5	Impeller
6	Inlet
7	Outlet

RELY ON EXCELLENCE

## Product variants

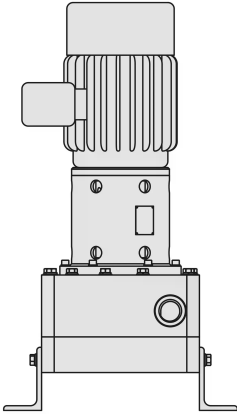

Blower type: Two stage centrifugal  
Speed: min. 750 min<sup>-1</sup>, max. 6,000 min<sup>-1</sup>  
Design pressure: Atmospheric to 69 barg (1,000 PSIG)  
Design temperature: 80 °C (176 °F)  
Max. gas density: 32 kg/m<sup>3</sup> (2 lbft<sup>3</sup>)  
Motor size:  
230/460 V, 3 phase, 60 Hz, 2.2 kW (3 hp)  
Size: height 84 cm (33"), depth 32 cm (12.5"), length 47 cm (18.5")  
Weight: 204 kg (450 lb)

## Charts

Performance curves for type 172-0500