

RELY ON EXCELLENCE

## MagBlower model 157

### Blowers



#### Features

- Belt driven design
- Hermetically sealed
- No contamination of process
- No process gas to atmosphere
- Always below 85 dBA noise levels
- Low heat generation and high torque transfer magnetic coupling
- Pulsation free gas flow
- Engineered designs available to meet special requirements

#### Functional description

The Magnetic coupling allows power transfer from the electric motor to the impeller without mechanical contact; eliminating the need for a shaft seal. The bearings suitable for the application support the impeller shaft in the blower housing. The gas enters the blower and the energy put into the gas from the blower impeller, produces flow and a pressure increase as required for the application before exiting the blower outlet.

#### Notes

Options:

- Horizontal or vertical design

#### Advantages

- The MagBlower delivers abundant, reliable, and consistent gas flow, in every situation with no leakage.
- Simple to set-up, easy to operate
- High reliability and availability
- Designed for continuous operation
- Low maintenance costs
- Energy efficient

#### Operating range

Pressure: Vacuum ... 1,100 bar (15,954 PSI)

Temperature:

-40 °C ... +200 °C (-40 °F ... +392 °F)

Head: ... 1.7 Kpa (0.25 PSI) on air

Flow: 190 m<sup>3</sup>/h (112 CFM) on air

Models outside of these operating ranges are available on request.

#### Recommended applications

- Oil and gas industry
- Refining technology
- Chemical industry
- Petrochemical industry
- Pharmaceutical industry
- Nuclear applications
- Research
- Manufacturing
- Vapor recovery

## RELY ON EXCELLENCE

- Centrifugal or regenerative impeller
- Single to four stage in series or parallel
- Bearings to meet application requirements
- Noise reduction cover

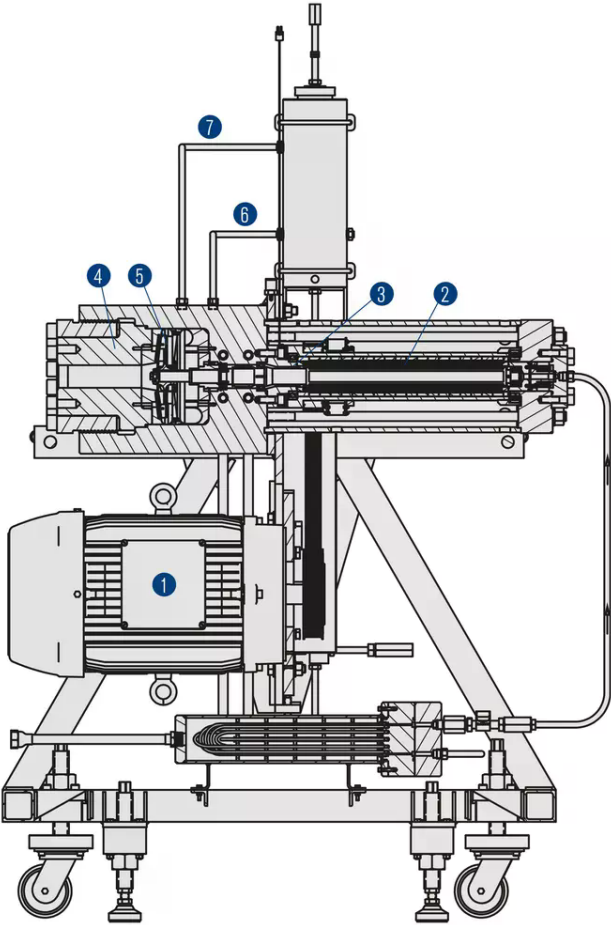

Item	Description
1	Motor
2	Magnetic coupling
3	Bearing assembly
4	Blower housing
5	Impeller
6	Inlet
7	Outlet

RELY ON EXCELLENCE

## Product variants

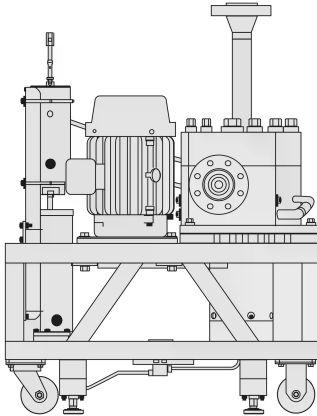

Blower type: Single stage, centrifugal  
 Speed: min. 1,200 min<sup>-1</sup>, max. 3,600 min<sup>-1</sup>  
 Design pressure: Atmospheric to 303 barg (4,400 PSIG)  
 Design temperature: 460 °C (860 °F)  
 Bearing cooling: Oil lubrication system  
 Motor size:  
 230/460 V, 3 phase, 60 Hz, 22 kW (30 hp)  
 Size: height 170 cm (67"), depth 69 cm (27") w/o outlet flange, length 132 cm (27")  
 Weight: approx. 1,400 kg (3,100 lb)

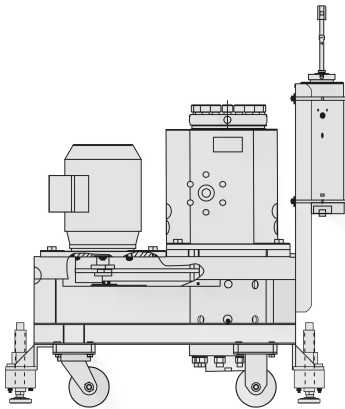

Blower type: Single stage, centrifugal  
 Speed: min. 1,800 min<sup>-1</sup>, max. 3,600 min<sup>-1</sup>  
 Design pressure: Atmospheric to 1,000 barg (14,504 PSIG)  
 Design temperature: 300 °C (572 °F)  
 Bearing cooling: Oil lubrication system  
 Max. gas density: 362 kg/m<sup>3</sup> (22.6 lb/ft<sup>3</sup>)  
 Motor size:  
 415 V, 3 phase, 50 Hz, 11 kW (15 hp)  
 Size: height 139 cm (54.5"), depth 69 cm (27"), length 112 cm (44")  
 Weight: 790 kg (1739 lb)

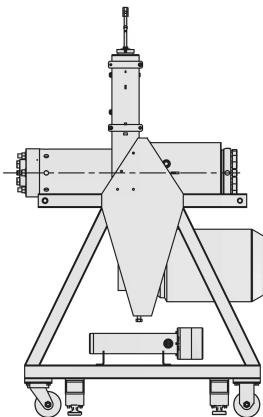

Blower type: Single stage, centrifugal  
 Speed: min. 1,800 min<sup>-1</sup>, max. 5,000 min<sup>-1</sup>  
 Design pressure: Atmospheric to 690 barg (10,000 PSIG)  
 Design temperature: 150 °C (302 °F)  
 Bearing cooling: Oil lubrication system  
 Motor size:  
 415 V, 3 phase, 50 Hz, 30 kW (40 hp)  
 Size: height 226 cm (89"), depth 81 cm (32"), length 152 cm (60")  
 Weight: 1,380 kg (3,040 lb)

RELY ON EXCELLENCE

---

## Charts

Performance curves for type 157-0200

Performance curves for type 157-0300

Performance curves for type 157-0500