

RELY ON EXCELLENCE

## MagBlower model 120

### Blowers



#### Features

- Hermetically sealed
- No contamination of process
- No process gas to atmosphere
- Always below 85 dBA noise levels
- Low heat generation and high torque transfer magnetic coupling
- Pulsation free gas flow
- Engineered designs available to meet special requirements

#### Functional description

The Magnetic coupling allows power transfer from the electric motor to the impeller without mechanical contact; eliminating the need for a shaft seal. The bearings suitable for the application support the impeller shaft in the blower housing. The gas enters the blower and the energy put into the gas from the blower impeller, produces flow and a pressure increase as required for the application before exiting the blower outlet.

#### Notes

Options:

- Horizontal or vertical design
- Centrifugal or egenerative impeller

#### Advantages

- The MagBlower delivers abundant, reliable, and consistent gas flow, in every situation with no leakage.
- Simple to set-up, easy to operate
- High reliability and availability
- Designed for continuous operation
- Low maintenance costs
- Energy efficient

#### Operating range

Pressure: Vacuum ... 3.45 bar (50 PSI)

Temperature:

-40 °C ... +200 °C (-40 °F ... +392 °F)

Head: ... 83 Kpa (12 PSI) on air

Flow: 900 m<sup>3</sup>/h (530 CFM) on air

Models outside of these operating ranges are available on request.

#### Recommended applications

Blowers can be used for many applications and these are a few of the possible areas:

- Nuclear applications
- Oil and gas industry
- Refining technology
- Chemical industry
- Petrochemical industry
- Pharmaceutical industry
- Aerospace industry
- Research
- Manufacturing
- Vapor recovery

## RELY ON EXCELLENCE

- Single to four stage in series or parallel
- Bearings to meet application requirements
- Noise reduction cover

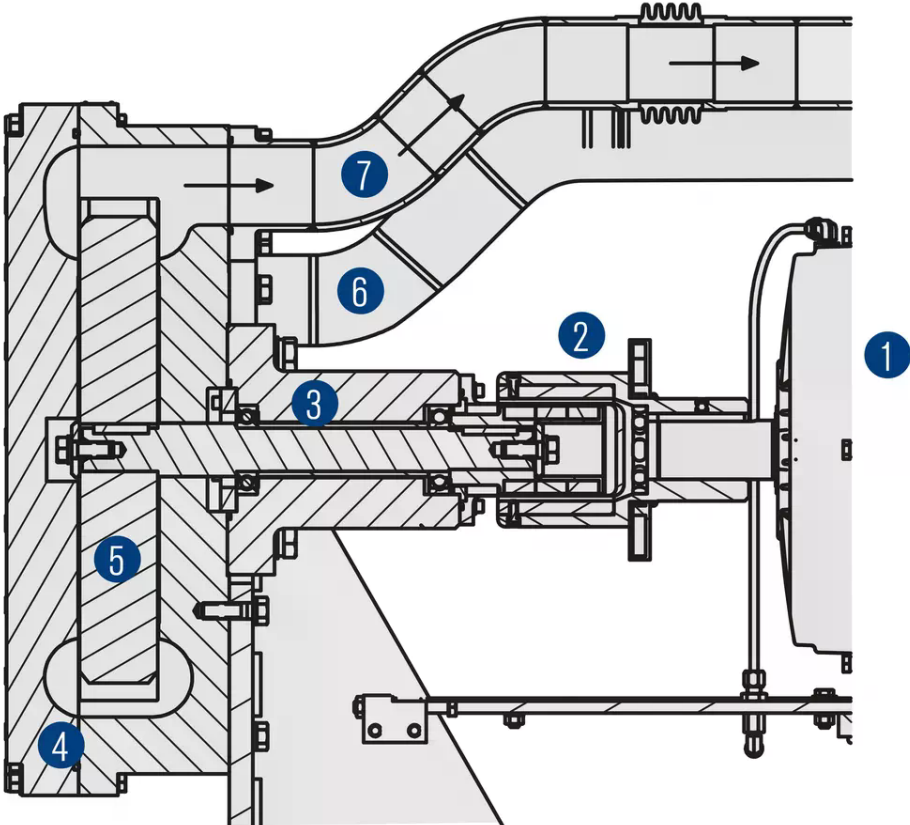

Item	Description
1	Motor
2	Magnetic coupling
3	Bearing assembly
4	Blower housing
5	Impeller
6	Inlet
7	Outlet

RELY ON EXCELLENCE

## Product variants

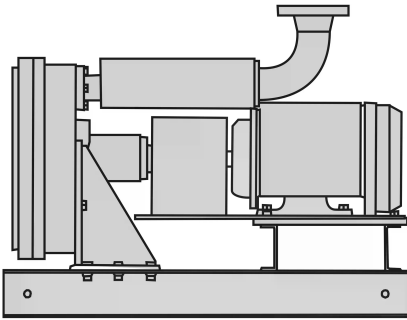

Blower Type: Single stage regenerative  
Speed: min. 2,000 min<sup>-1</sup>, max. 4,200 min<sup>-1</sup>  
Design pressure: Vacuum ... 2.1 barg (30 PSIG)  
Design temperature: +80 °C (+176 °F)  
Noise level: 80 dBA at 2,900 min<sup>-1</sup>  
Motor size: 230/460 V, 3 phase, 60 Hz, 11 kW (15 hp)  
Size: height 72 cm (28"),  
(84 cm (33") with silencer),  
depth 56 cm (22"), length 135 cm (53")  
Weight: 340 kg (750 lb)

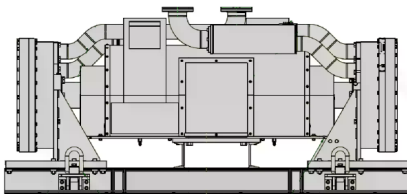

Blower Type: Two stage regenerative  
Speed: min. 1,200 min<sup>-1</sup> max. 4,500 min<sup>-1</sup>  
Design pressure:  
Vacuum ... 3.45 barg (50 PSIG)  
Design temperature: +200 °C (+392 °F)  
Bearing cooling: Water jacket  
Leak rate: <math>1 \times 10^{-7}</math> cc/s helium  
Noise level:  
85 dBA at 4,300 min<sup>-1</sup> with enclosure  
Motor size:  
230/460 V, 3 phase, 60 Hz, 30 kW (40 hp)  
Size: height and depth 92 cm (36"),  
length 200 cm (79")  
Weight: 1,290 kg (2,840 lb)

## Charts

Performance curves for type 120-0800

Performance curves for type 120-0700