

RELY ON EXCELLENCE

ZY6 Cyclone separator

API 682 4th edition product range | Seal supply systems | Separators



Features

The ZY6A4 range is available in three versions:

ZYA6000A4

Cyclone separator for high flow rates and high pressures.

ZYB6000A4

Cyclone separator for high flow rates and high pressures; 100 % X-ray capability.

ZYC6000A4

Cast version, block-type design with integral flanges.

Functional description

Cyclone separators of the ZY6A4 range are used to clean mainly aqueous liquids containing contamination such as dirt and solids (e.g., in circulation systems of sewage, sludge or pipeline pumps).

The best possible filtration efficiency is achieved when the specific weight of the solids is much higher than that of the carrier liquid and when the differential pressure is as large as possible within the permissible pressure range (min. 1.7 bar (24.7 PSI) in accordance with API 682). The viscosity of the medium is a factor that also needs to be taken into account.

Advantages

- Contamination is automatically conveyed to the suction nozzle of the pump: maintenance-free mode of operation for guaranteed reliability
- High filtration efficiency
- Wide range of products for the optimum solution for every application
- ZYA6000A4 and ZYB6000A4: available for operating pressures of up to 200 bar (2,900 PSI)
- ZYC6000A4 in block-type design with integrated flange connections: low space requirements because of compact design

Recommended applications

- Refining technology
- Oil and gas industry
- Petrochemical industry
- Chemical industry
- Power plant technology

Recommended piping plans

API Plan 31

API Plan 41

RELY ON EXCELLENCE

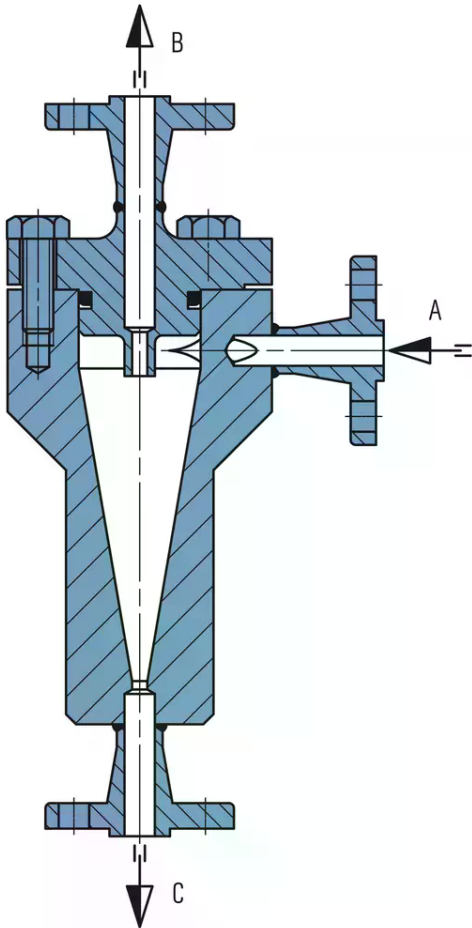

ZYA6000A4

- A Contaminated liquid IN
- B Clean liquid OUT
- C Separated liquid OUT

RELY ON EXCELLENCE

Installation, details, options

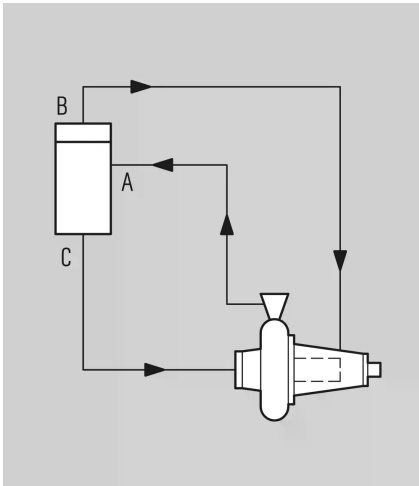

**P&ID for ZY6000A4
Cyclone separators**

- A Contaminated liquid IN
- B Clean liquid OUT
- C Separated liquid OUT

RELY ON EXCELLENCE

Product variants

Designation	ZYA6000A4	ZYB6000A4	ZYC6000A4
Features	Standard	100 % X-ray capable	Cast version
Connections -product inlet	Flange 3/4",600 lbs	Flange 3/4",600 lbs	Integrated flange 3/4",600 lbs
Connections -clean product outlet	Flange 3/4",600 lbs	Flange 3/4",600 lbs	Integrated flange 3/4",600 lbs
Connections -contaminated product outlet	Flange 3/4",600 lbs	Flange 3/4",600 lbs	Integrated flange 3/4",600 lbs
Allowable pressure ¹⁾	60 bar(870 PSI)	60 bar(870 PSI)	60 bar(870 PSI)
Temperature range	-29 °C ... +150 °C(-20 °F ... +302 °F)	-29 °C ... +150 °C(-20 °F ... +302 °F)	-29 °C ... +150 °C(-20 °F ... +302 °F)
O-Ring ²⁾	Viton®	Viton®	Viton®
Wetted parts	316/316L	316/316L	316/316L

Other versions on request.

1) Max. permissible working values depend on version.

2) Other materials on request, e.g., EPDM, FFKM

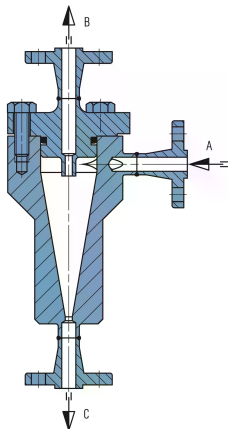

ZYB6000A4

Cyclone separator for high flow rates and high pressures; 100 % X-ray capability.

RELY ON EXCELLENCE

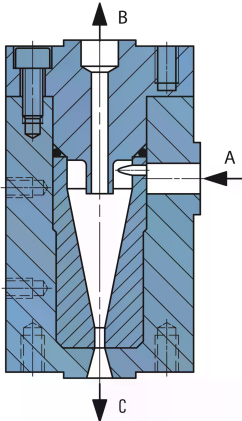

ZYC6000A4
Cast version, block-type design with integrated flanges.