

RELY ON EXCELLENCE

LSC6 Leakage collection reservoir

API 682 4th edition product range | Seal supply systems |
Leakage detection and collection



Advantages

- Leakage collection tank with sight-glass
- Modular system: combination with a wide range of monitoring instruments possible

Standards and approvals

- API 682 / ISO 21049
- API 682 4th ed. Cat. 2/3 - 2CW-CS

Recommended applications

- Refining technology
- Oil and gas industry
- Petrochemical industry
- Chemical industry
- Power plant technology

Recommended piping plans

API Plan 75

Features

The EagleBurgmann leakage control systems of the LSC6000A4 range are utilized to collect condensing or mixed phase leakage - vapor passing through. A level indicator is installed to determine when the tank needs to be drained. A pressure gauge tracks and indicates seal leakage.

Functional description

The LSC6000-A4 leakage control system is used to discharge leakage from liquid-lubricated single seals with downstream safety gas seals where the leakage is liquid under atmospheric conditions.

Notes

Design and production in accordance with EU Pressure Equipment Directive PED 2014/68/EU available.

Design, calculation and production acc. to ASME VIII, Div. 1 available.

3rd party inspection, ASME stamp on request.

RELY ON EXCELLENCE

LSC6000A4

- A From mechanical seal
- B To vapor collection system
- C Drain

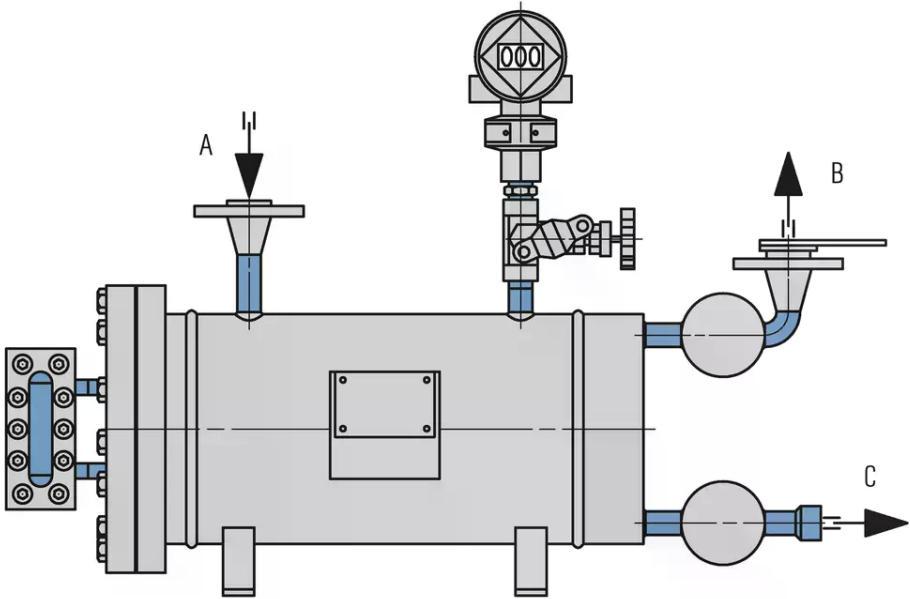

Installation, details, options

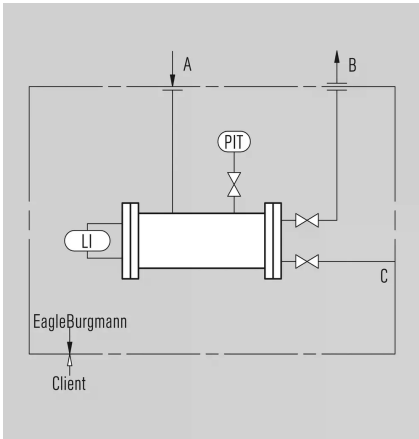

P&ID for LSC6000A4
Leakage collection Reservoir

- A From mechanical seal
- B To vapor collection system
- C Drain

RELY ON EXCELLENCE

Product variants

Designation	LSC6000A4
Pressure Equipment Directive	PED 2014/68/EU ASME VIII, Div.1
Volume of vessel	14 l
Allowable pressure ¹⁾	44 bar (638 PSI)
Allowable temperature ¹⁾	-20 °C ... +120 °C (-4 °F ... +248 °F)
Connection seal leakage	Flange 3/4", 600 lbs
Connection collecting system for condensing leakages	3/4" NPT(f)
Connection fluids collection system	Flange 3/4", 600 lbs
Metal parts	316/316L
Gaskets	PTFE, Burasil, Viton®, FKM

Other versions on request.

1) Design data, permissible working values depend on the actual conditions of service.